

**PLAN OF ROOF SLAB**

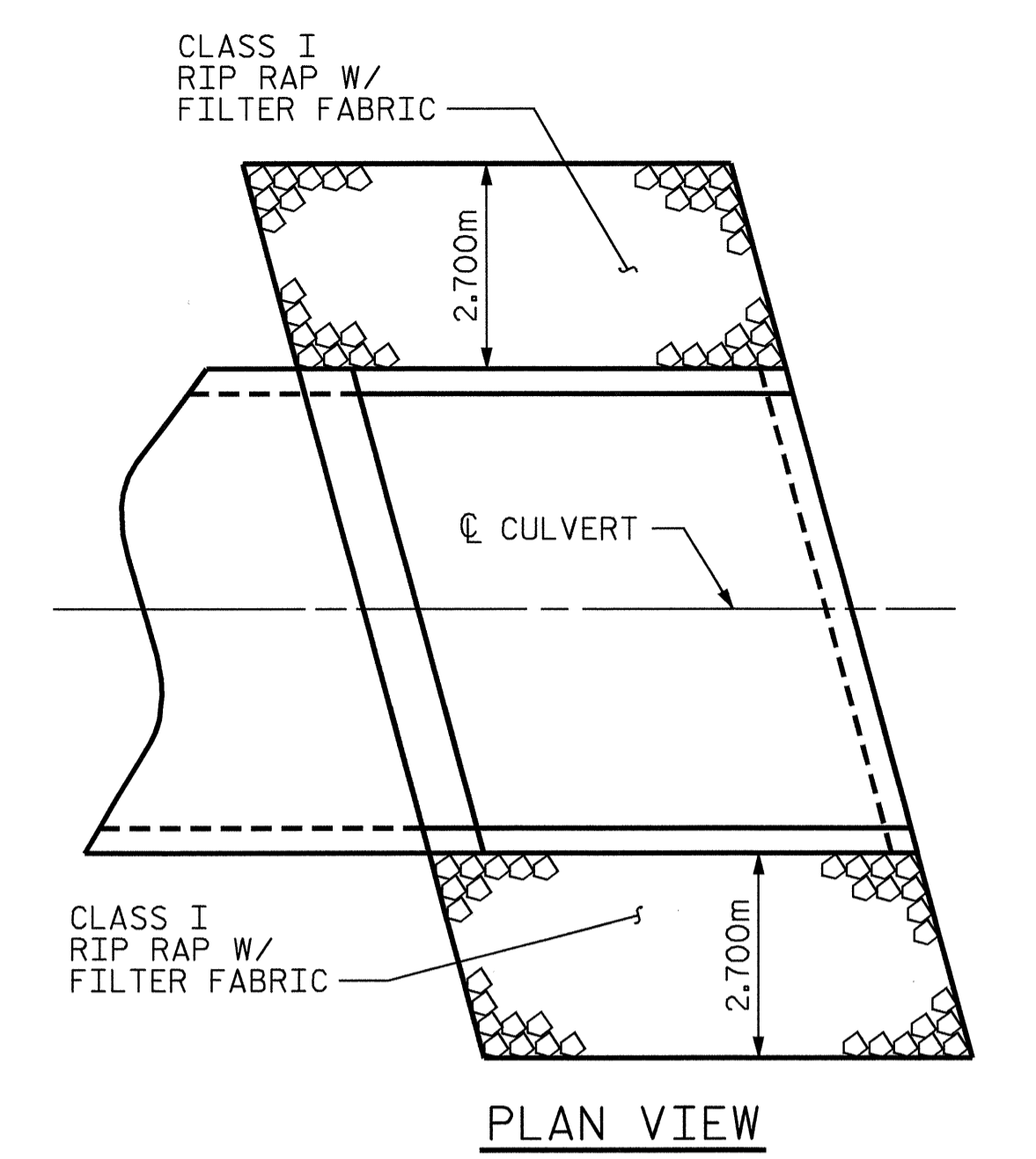

**PLAN VIEW**

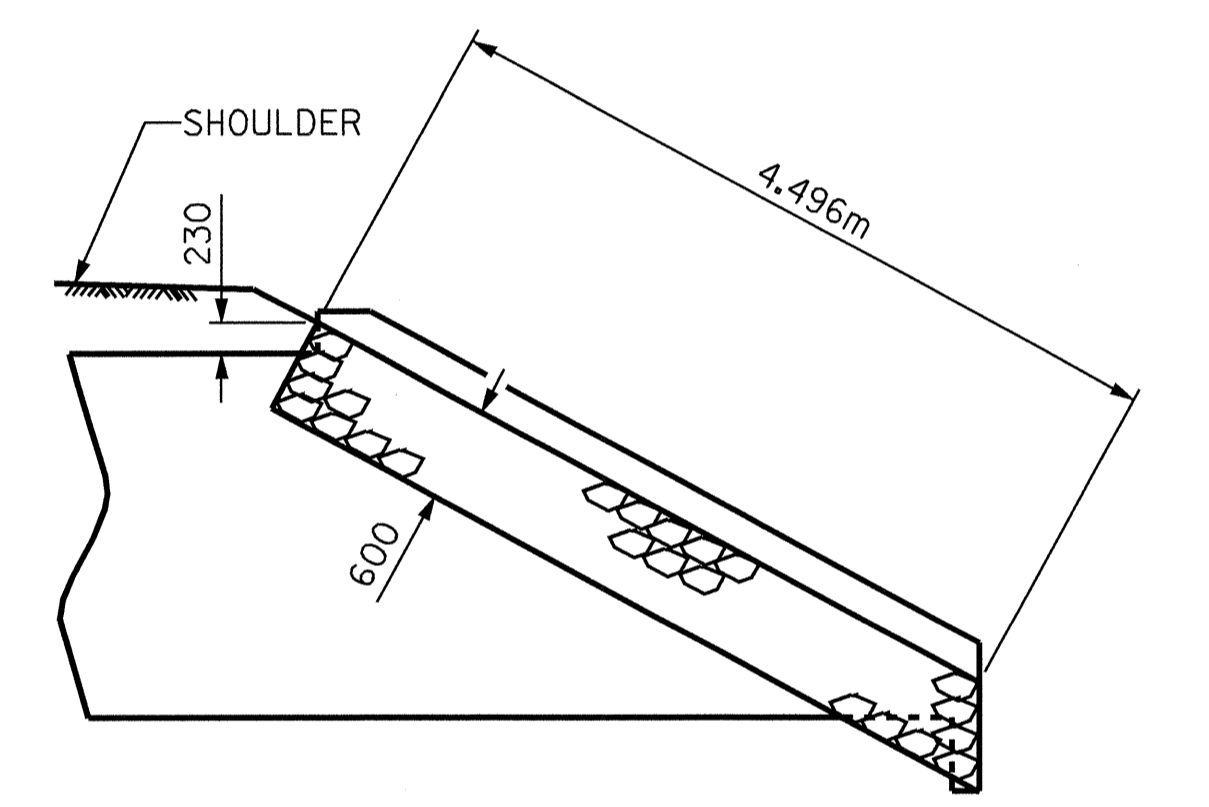

**ELEVATION VIEW**

**OUTLET WING RIP RAP DETAILS**

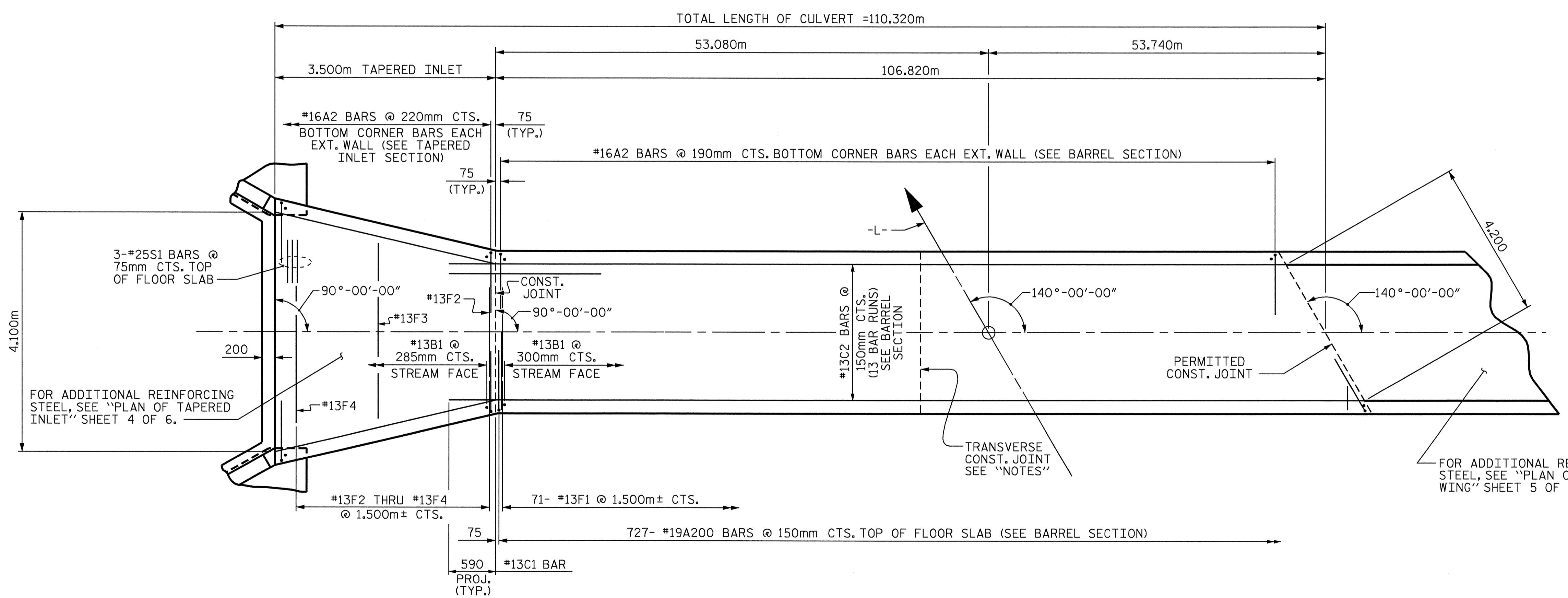

**PLAN OF FLOOR SLAB**

NOTE: FIELD BEND #13C1 BARS IN EXT. WALL AS NECESSARY

PROJECT NO. R-2206B  
LINCOLN COUNTY  
 STATION: 158+95.000 -L-

SHEET 3 OF 6

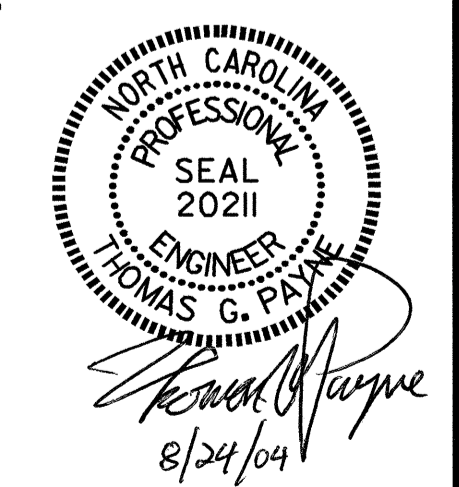

STATE OF NORTH CAROLINA DEPARTMENT OF TRANSPORTATION RALEIGH					
SINGLE 2.7m X 1.8m CONCRETE BOX CULVERT WITH TAPERED INLET					
SHEET NO. <b>C-12</b>					
TOTAL SHEETS <b>15</b>					
REVISIONS					
NO.	BY:	DATE:	NO.	BY:	DATE:
1			3		
2			4		

DRAWN BY: D.B. MOORE DATE: 3-22-01  
 CHECKED BY: M.J. OSTRISHKO DATE: 4-03-01