

EXTERIOR GIRDER

INTERIOR GIRDER

DETAIL OF REQUIRED OVERHANG FALSEWORK BRACING SYSTEM

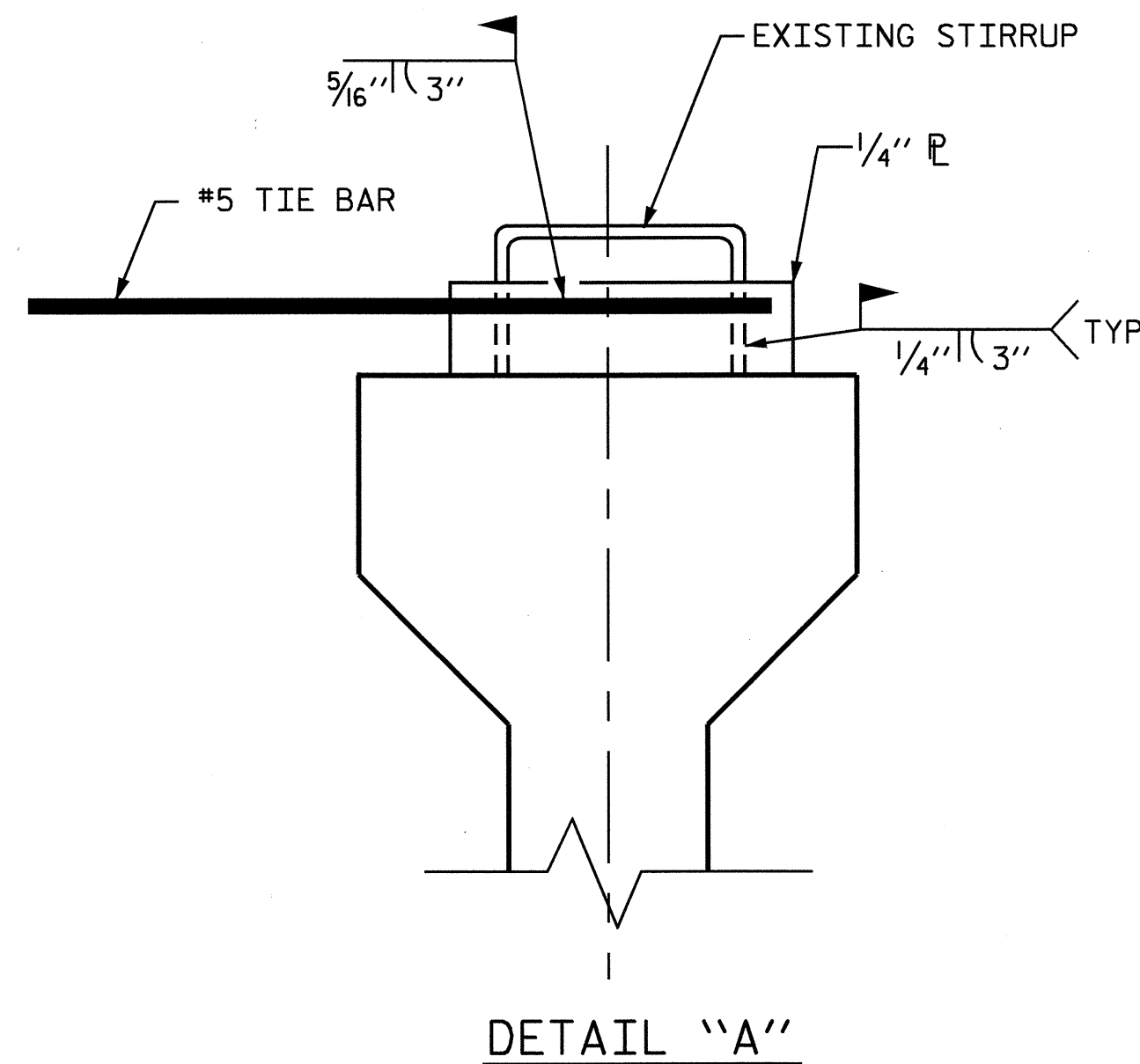

DETAIL "A"

NOTES:

EACH #5 TIE BAR SHALL BE WELDED TO ONE STIRRUP LOOP AS SHOWN IN DETAIL "A". #5 TIE BARS SHALL BE WELDED TO TWO ADJACENT STIRRUPS OF THE EXTERIOR GIRDER AND THE ADJACENT INTERIOR GIRDER BETWEEN PERMANENT DIAPHRAGMS. WELD STEEL PLATES IN BETWEEN THE TIE BARS AND THE STIRRUP LOOP. WELDING TWO TIE BARS TO THE SAME STIRRUP LOOP SHALL NOT BE PERMITTED.

MAXIMUM SPACING BETWEEN THE BRACING (TIE BARS-TIMBER STRUT) IS 8'-0" CTS. #5 TIE BARS SHALL BE LOCATED OVER A TIMBER STRUT.

INSTALL TIE BARS AND TIMBER STRUTS PRIOR TO PLACEMENT OF CONCRETE OR SCREED WEIGHT ONTO THE OVERHANG FALSEWORK.

PROJECT NO. R-2206C
LINCOLN/CATAWBA COUNTY
 STATION: 256+91.000 -L-

SHEET 3 OF 3

STATE OF NORTH CAROLINA
 DEPARTMENT OF TRANSPORTATION
 RALEIGH

STANDARD OVERHANG FALSEWORK

AASHTO TYPES
 III, IV, V, AND VI

(RIGHT LANE)



Chang-Chun Victor Chang
 9-14-2004

REVISIONS						SHEET NO. 8-374
NO.	BY:	DATE:	NO.	BY:	DATE:	
1			3			TOTAL SHEETS 374
2			4			

DRAWN BY: R. WRIGHT 06/04 DATE : _____
 CHECKED BY: V. CHAO 06/04 DATE : _____

14-SEP-2004 08:13
 w:\squadd\BOB\FOR VICTOR\R2206C-OverHangSheets.dgn
 rwwright