

NOTES

ALL PRESTRESSING STRANDS SHALL BE 7-WIRE LOW-RELAXATION GRADE 270 STRANDS AND SHALL CONFORM TO AASHTO M203M EXCEPT FOR SAMPLING REQUIREMENTS WHICH SHALL BE IN ACCORDANCE WITH THE STANDARD SPECIFICATIONS.

TIE ROD ASSEMBLY SHALL BE AASHTO M270 GRADE 250 STRUCTURAL STEEL.

ALL REINFORCING STEEL SHALL BE GRADE 420.

APPLY EPOXY PROTECTIVE COATING TO END OF GIRDER SURFACES INDICATED IN ELEVATION VIEW. FOR EPOXY PROTECTIVE COATING, SEE SPECIAL PROVISIONS.

EMBEDDED PLATE "B-1" SHALL BE GALVANIZED IN ACCORDANCE WITH THE SPECIFICATIONS. BEVEL EDGES OF PLATE "B-1" TO GIVE CLOSE FIT BUT NOT TIGHT FIT TO STEEL CASTING FORM.

ANCHOR STUDS SHALL CONFORM TO AASHTO M169 GRADES 1010 THROUGH 1020 OR APPROVED EQUAL, AND SHALL MEET THE TYPE "B" REQUIREMENTS OF SUBSECTION 7.3 OF THE ANSI/AASHTO/AWS D1.5 BRIDGE WELDING CODE.

AT ENDS OF GIRDERS TO BE EMBEDDED IN CONCRETE DIAPHRAGMS OR END WALLS, PRESTRESSING STRANDS MAY EXTEND A MAXIMUM OF 50mm BEYOND THE GIRDER ENDS. OTHERWISE, PRESTRESSING STRANDS SHALL BE CUT FLUSH WITH THE GIRDER ENDS.

THE TRANSFER OF LOAD FROM THE ANCHORAGES TO THE GIRDER SHALL BE DONE WHEN CONCRETE HAS REACHED A COMPRESSIVE STRENGTH OF NOT LESS THAN 27.6 MPa FOR SPANS A AND C, AND 31.0 MPa FOR SPAN B.

DEPENDING ON THE TYPE OF SYSTEM USED TO SUPPORT THE DECK SLAB FORMS, PRESET ANCHORS MAY BE NECESSARY IN THE PRESTRESSED CONCRETE GIRDER.

THE TOP SURFACE OF THE GIRDER, EXCLUDING THE OUTSIDE 100mm, SHALL BE RAKED TO A DEPTH OF 6mm.

WHEN DRAPED STRANDS ARE DETAILED, THE LONGITUDINAL LOCATION OF THE HOLD DOWN DEVICES SHALL BE WITHIN 150mm OF THE LOCATION SHOWN AND THE CENTER OF GRAVITY OF THE GROUP OF DRAPED STRANDS SHALL BE LOCATED WITHIN 13mm OF THE THEORETICAL LOCATION SHOWN.

A 50mm x 50mm CHAMFER IS ALLOWED AT THE INTERSECTION OF THE WEB AND THE BOTTOM FLANGE OF THE 1600mm AND 1829mm MODIFIED BULB TEES ONLY.

FOR VERTICAL CRACKS IN PRESTRESSED CONCRETE GIRDERS PRIOR TO DETENSIONING, SEE SPECIAL PROVISIONS.

FOR PRESTRESSED CONCRETE MEMBERS, SEE SPECIAL PROVISIONS.

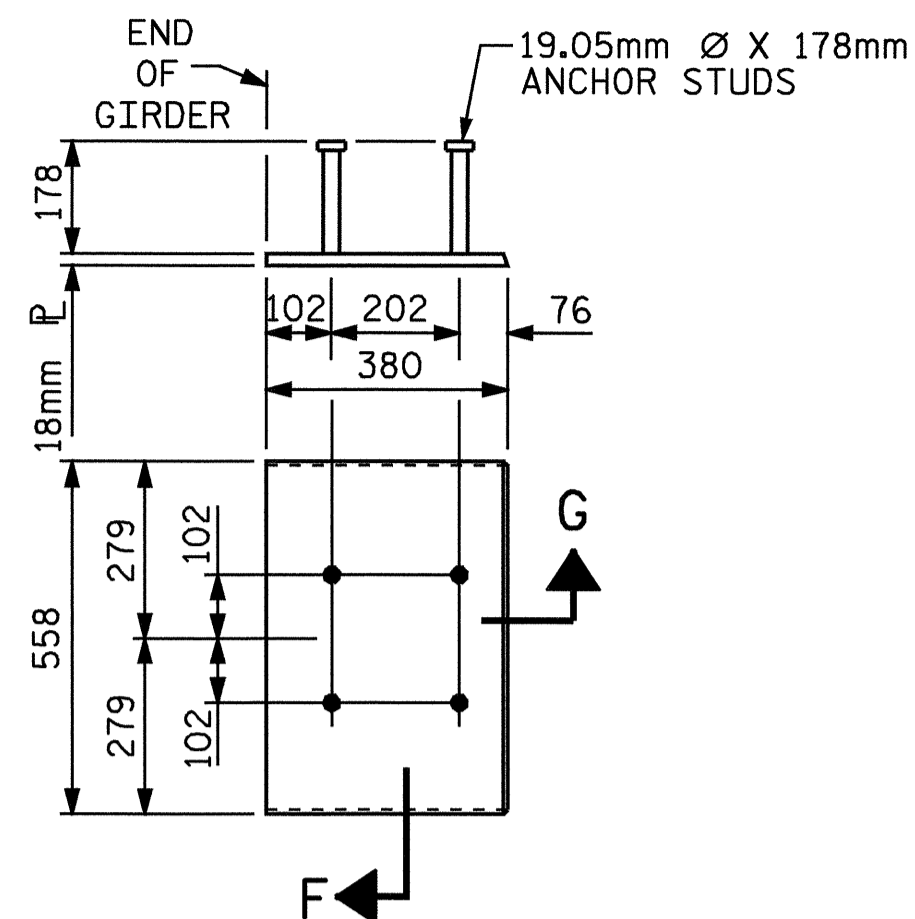

EMBEDDED PLATE "B-1" DETAILS FOR AASHTO TYPE III GIRDER
(2 REQ'D PER GIRDER)

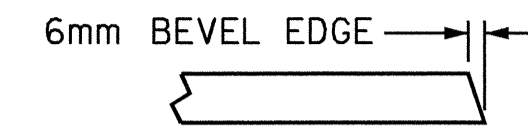
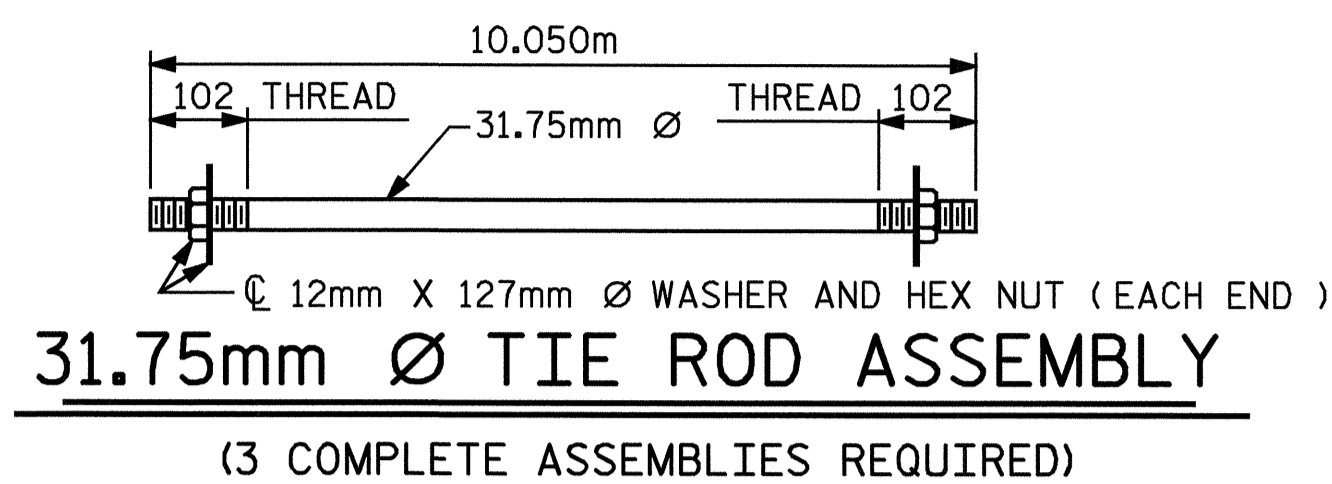

SECTION "G"

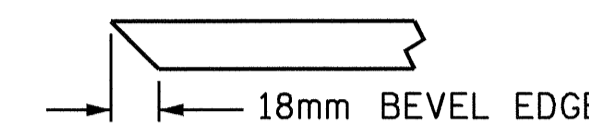

SECTION "F"

(SEE NOTES)

DEAD LOAD DEFLECTION TABLE FOR GIRDERS

| 12.70mm Ø LOW RELAXATION | SPAN A & C | | | | | | | | | | | SPAN B | | | | | | | | | | | |
|---------------------------------------|--------------|-------|-------|-------|-------|-------|-------|-------|-------|-------|-------|--------|-------|-------|-------|-------|-------|-------|-------|-------|-------|-------|-------|
| | ALL GIRDERS | | | | | | | | | | | | | | | | | | | | | | |
| | TENTH POINTS | 0 | .1 | .2 | .3 | .4 | .5 | .6 | .7 | .8 | .9 | 0 | 0 | .1 | .2 | .3 | .4 | .5 | .6 | .7 | .8 | .9 | 0 |
| CAMBER (GIRDER ALONE IN PLACE) | ↑ | 0.000 | 0.005 | 0.009 | 0.013 | 0.015 | 0.016 | 0.015 | 0.013 | 0.009 | 0.005 | 0.000 | 0.000 | 0.016 | 0.030 | 0.040 | 0.047 | 0.050 | 0.047 | 0.040 | 0.030 | 0.016 | 0.000 |
| * DEFLECTION DUE TO SUPERIMPOSED D.L. | ↓ | 0.000 | 0.002 | 0.004 | 0.006 | 0.007 | 0.008 | 0.007 | 0.006 | 0.004 | 0.002 | 0.000 | 0.000 | 0.005 | 0.010 | 0.013 | 0.016 | 0.017 | 0.016 | 0.013 | 0.010 | 0.005 | 0.000 |
| FINAL CAMBER | ↑ | 0 | 3 | 5 | 7 | 8 | 8 | 7 | 5 | 3 | 0 | 0 | 11 | 20 | 27 | 31 | 33 | 31 | 27 | 20 | 11 | 0 | |

* INCLUDES FUTURE WEARING SURFACE
ALL VALUES ARE SHOWN IN METERS, EXCEPT "FINAL CAMBER" WHICH IS SHOWN IN MILLIMETERS.

PROJECT NO. R-2206C
LINCOLN-CATAWBA COUNTY
STATION: 223+03.850 -L-

SHEET 3 OF 3

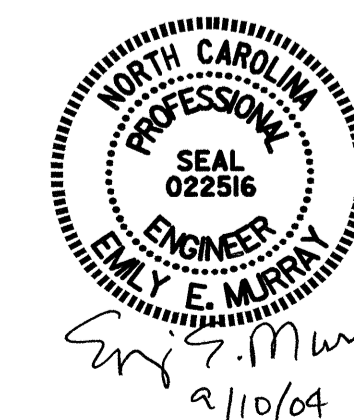

| | | | | | |
|--|-----|-------|-----|-----|---------------------|
| STATE OF NORTH CAROLINA DEPARTMENT OF TRANSPORTATION RALEIGH | | | | | |
| STANDARD PRESTRESSED CONCRETE GIRDER CONTINUOUS FOR LIVE LOAD DETAILS RIGHT LANE | | | | | |
| REVISIONS | | | | | SHEET NO. |
| NO. | BY: | DATE: | NO. | BY: | DATE: |
| 1 | | | 3 | | |
| 2 | | | 4 | | |
| | | | | | TOTAL SHEETS 374 |

| | |
|-----------------------------|-------------|
| ASSEMBLED BY : PEGGY ADKINS | DATE : 2-04 |
| CHECKED BY : T. AVERETTE | DATE : 3-04 |
| DRAWN BY : ELR | 11/91 |
| CHECKED BY : GRP | 11/91 |
| REV. 8/16/99 | MAB/LES |
| REV. 10/17/00 | RWW/LES |
| REV. 7/10/01 | LES/RDR |