

PLAN

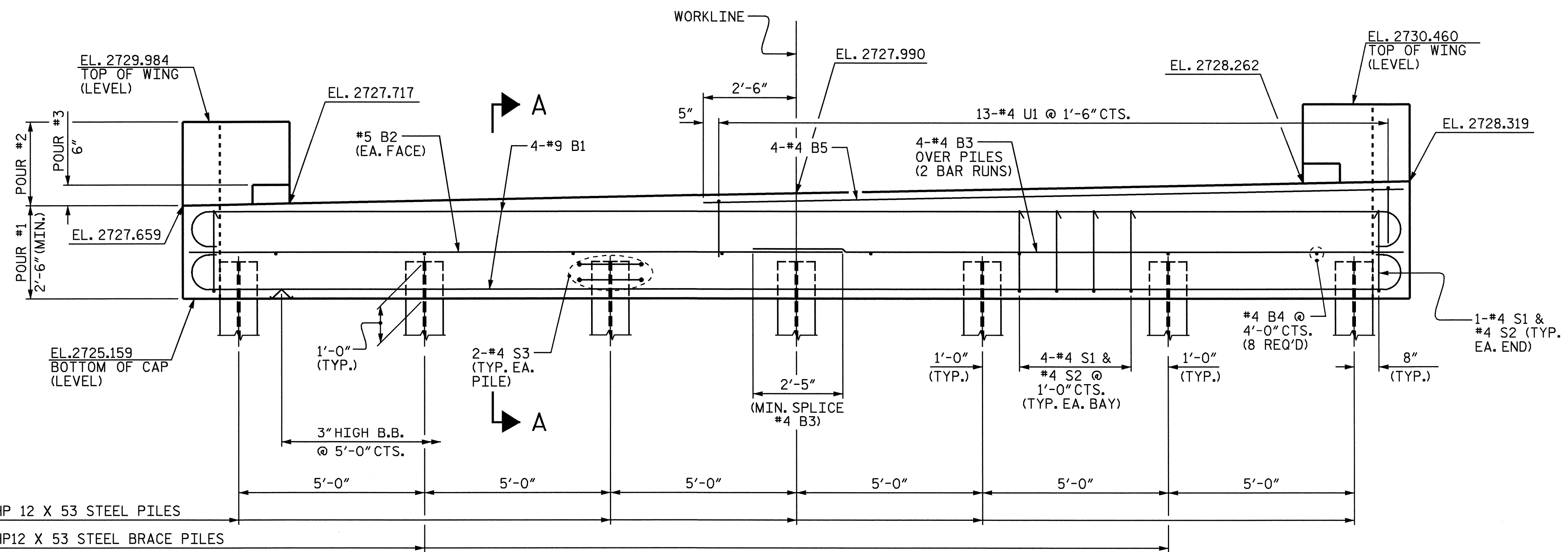

ELEVATION

NOTES

STIRRUPS IN CAP MAY BE SHIFTED AS NECESSARY TO CLEAR DOWELS.

THE LATERAL GUIDE AT THE END OF THE CAP IS NOT TO BE POURED UNTIL AFTER THE CORED SLAB UNITS ARE IN PLACE.

THE CONTRACTOR SHALL PROVIDE FOR INSTALLATION OF THE 4" DIAMETER DRAIN PIPE THROUGH THE WING WALL AS REQUIRED FOR REINFORCED BRIDGE APPROACH FILLS, SEE THE ROADWAY PLANS. REINFORCING STEEL IN THE WING WALL MAY BE SHIFTED AS NECESSARY TO CLEAR THE DRAIN PIPE.

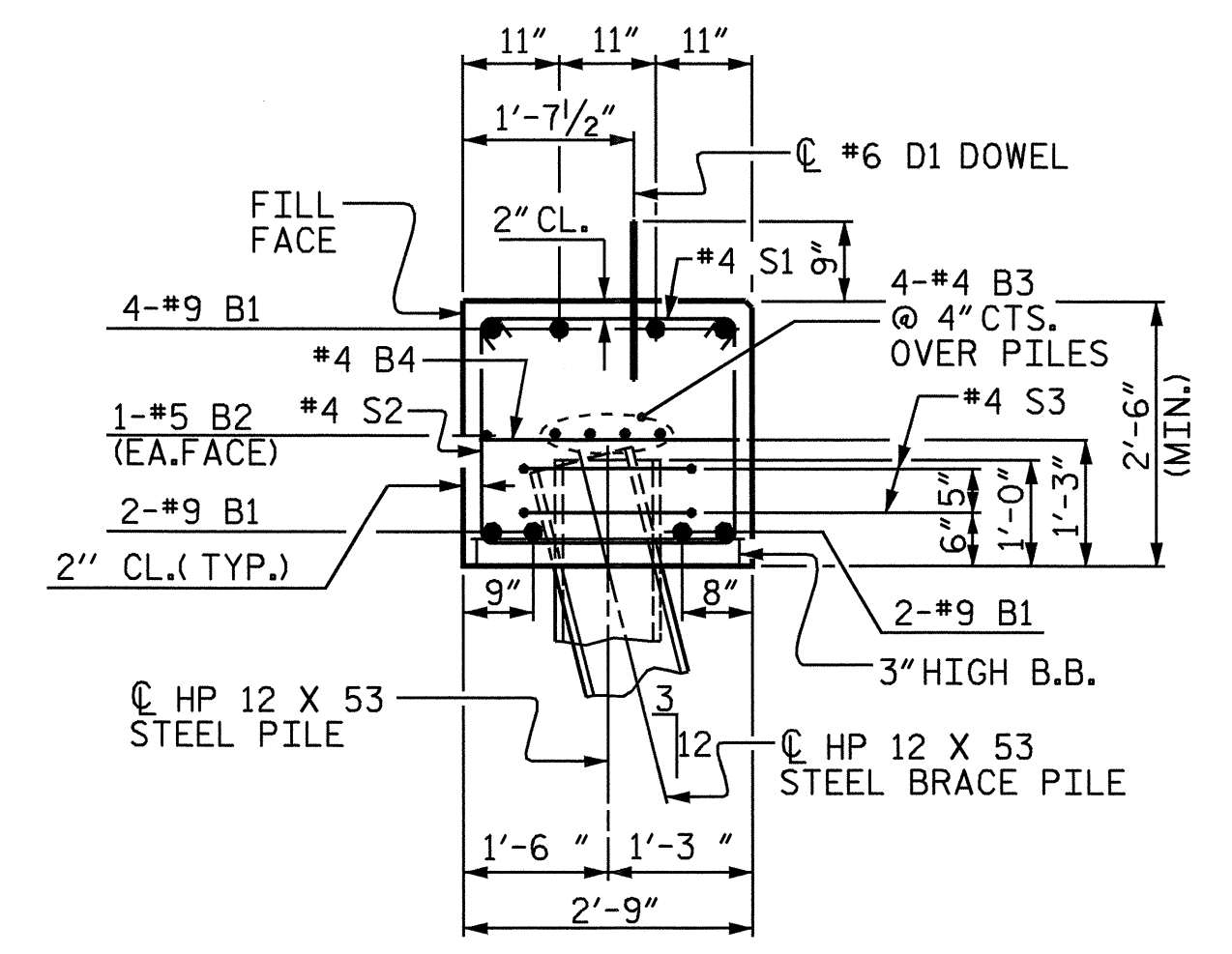

SECTION A-A

PROJECT NO. B-3667
JACKSON COUNTY
 STATION: 12+52.50 -L-

SHEET 1 OF 3

STATE OF NORTH CAROLINA
 DEPARTMENT OF TRANSPORTATION
 RALEIGH

**SUBSTRUCTURE
 END BENT 2**



DRAWN BY : K. McCAULEY DATE : 7/30/04
 CHECKED BY : A. L. MEADOWS DATE : 8/4/04

30-SEP-2004 08:53
 W:\sq\cdp\b3667\str\1\KMCCAU2\MICROS2\B3667.sd.E*.01.dgn
 kmccauley

REVISIONS						SHEET NO.	
NO.	BY:	DATE:	NO.	BY:	DATE:	S-14	
1			3			TOTAL SHEETS	
2			4			37	