

TYPICAL SECTION

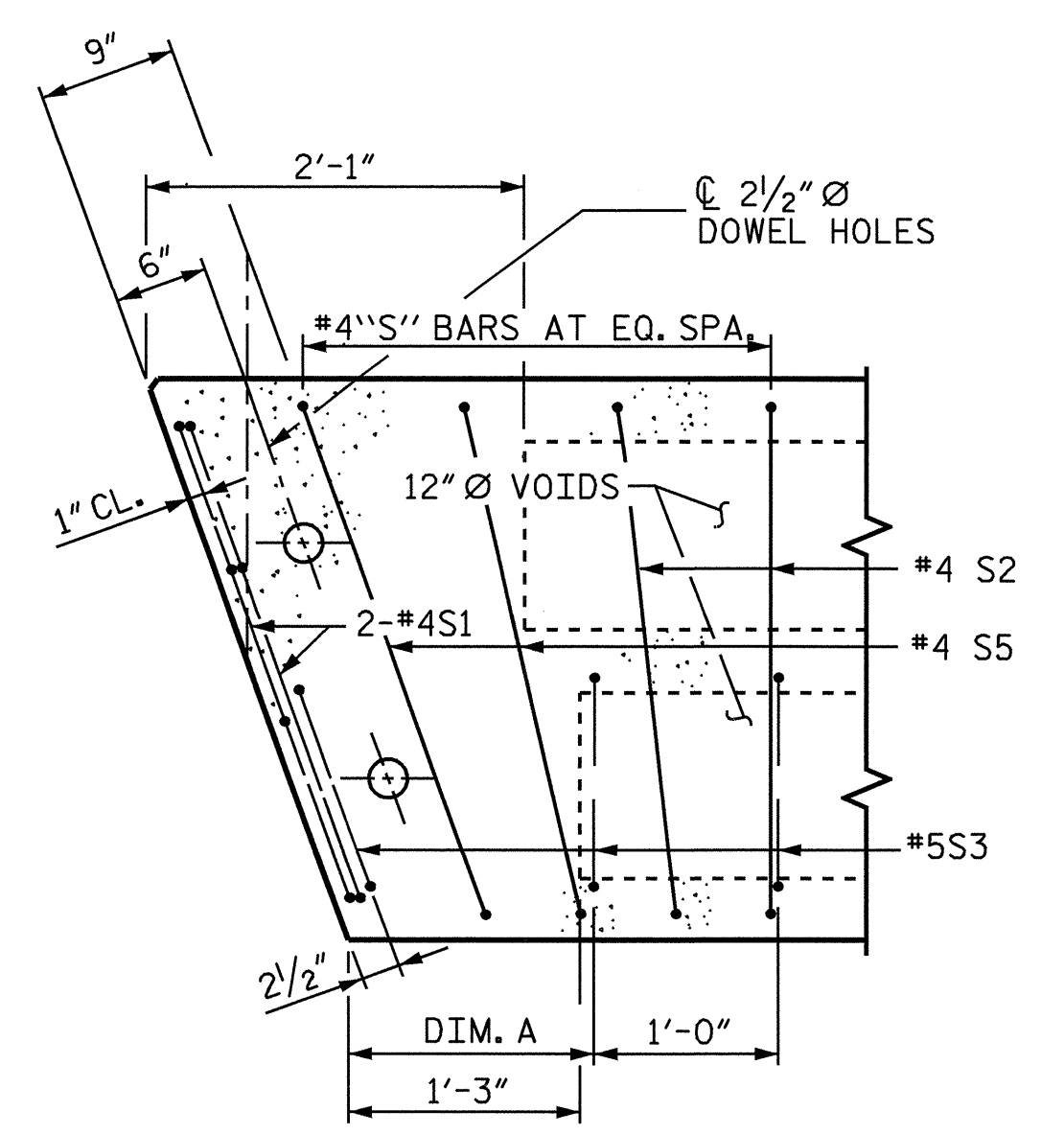

PART PLAN-EXTERIOR SECTION

NOTE: EXTERIOR SECTION SHOWN-INTERIOR SECTION SIMILAR EXCEPT OMIT S3 BARS. SEE PLAN OF SPAN FOR DIM. A.

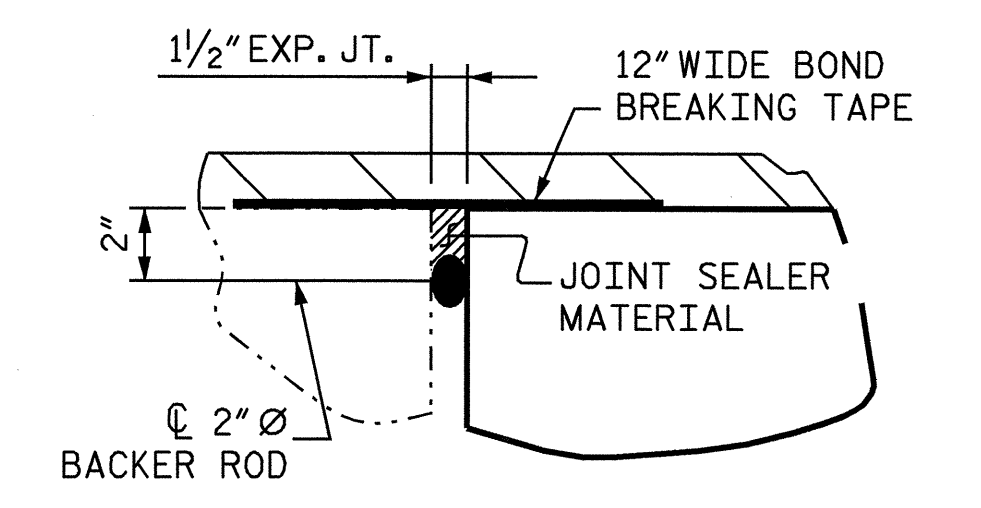

DETAIL A

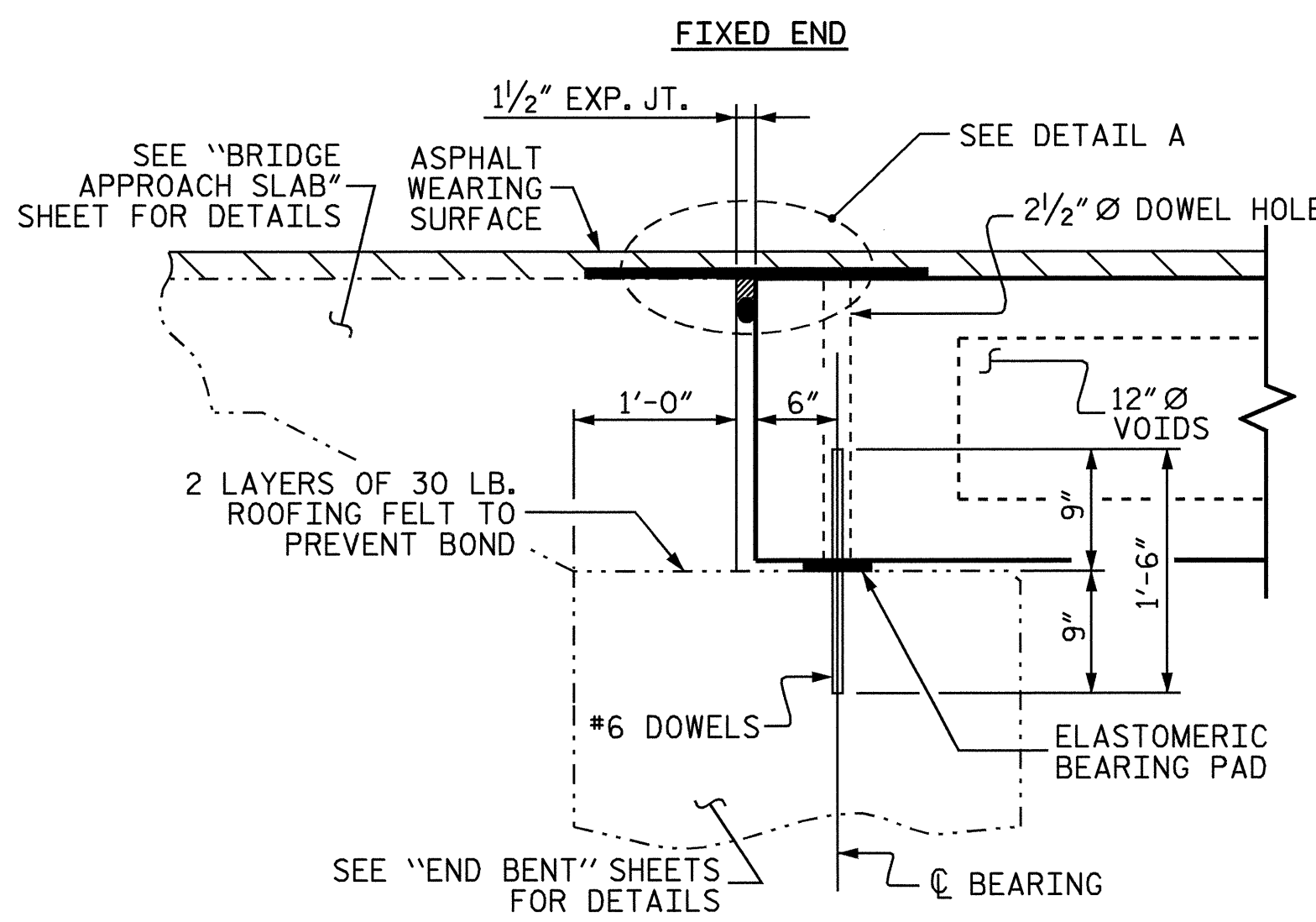

SECTION @ END BENT

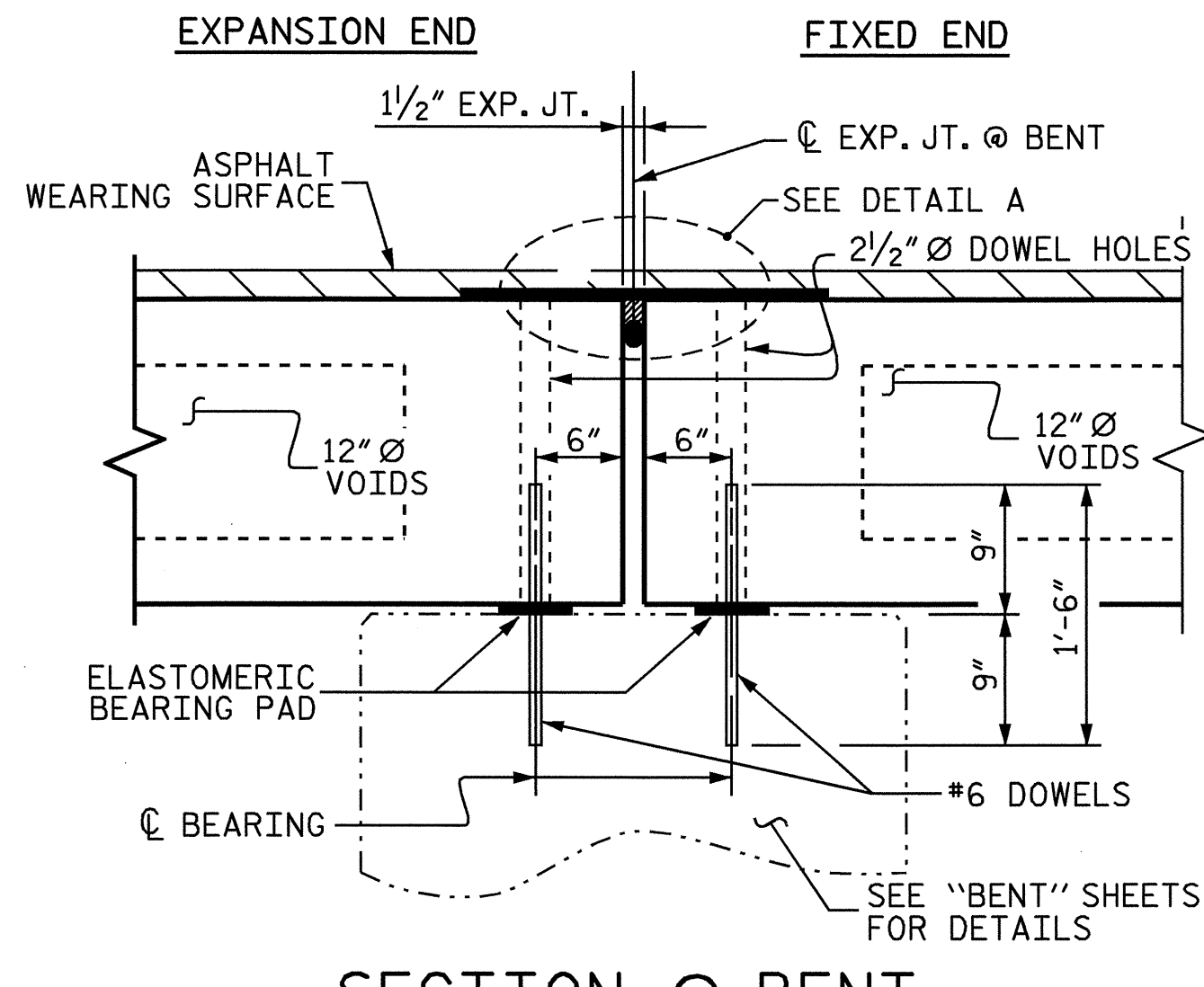

SECTION @ BENT

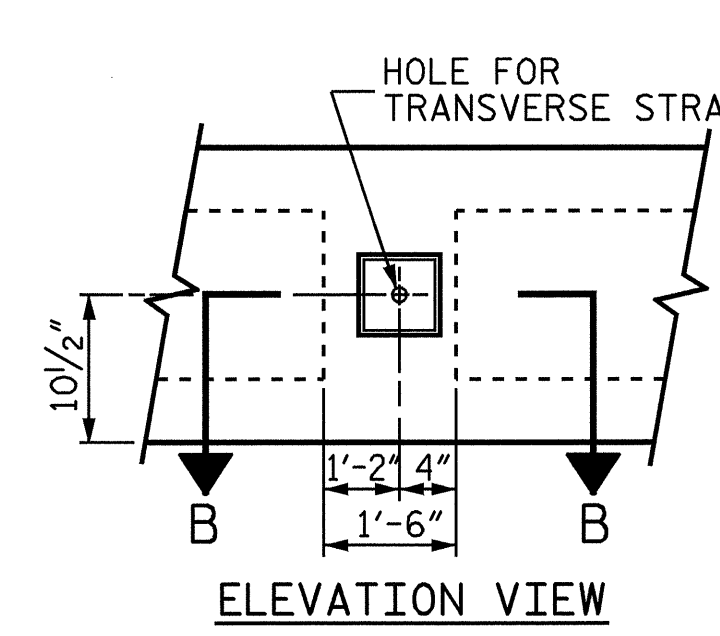

ELEVATION VIEW

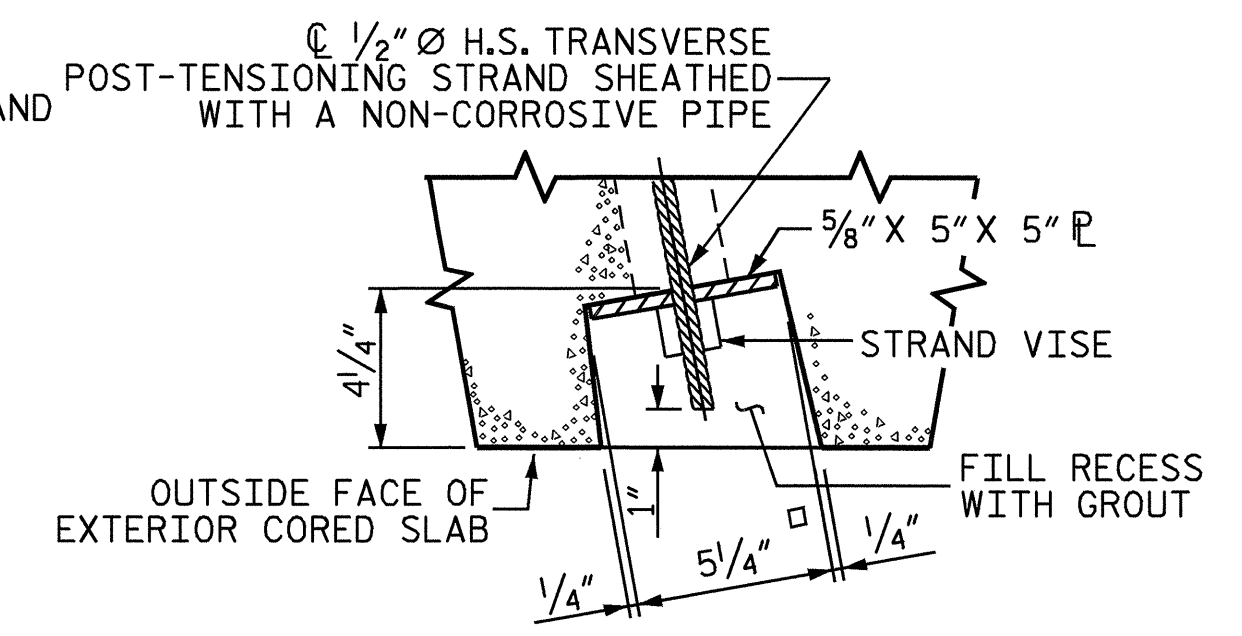

SECTION B-B

GROUTED RECESS AT END OF POST-TENSIONED STRAND CORED SLABS

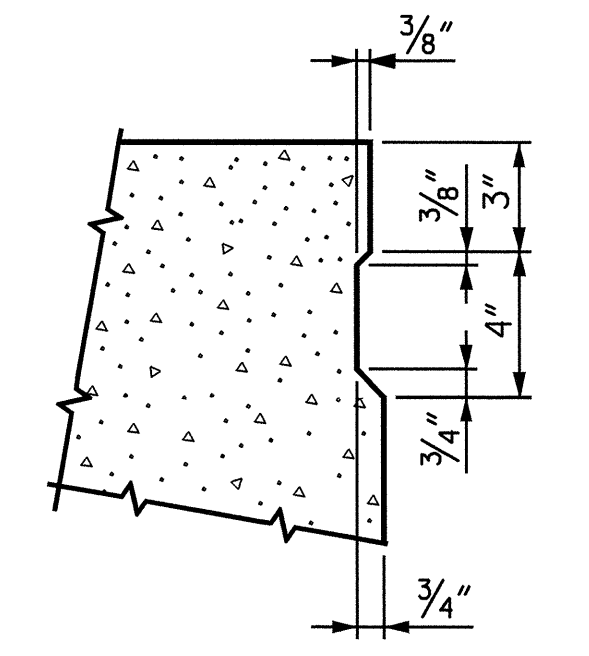

SHEAR KEY DETAIL

NOTE: OMIT SHEAR KEY ON OUTSIDE FACE OF EXTERIOR CORED SLABS.

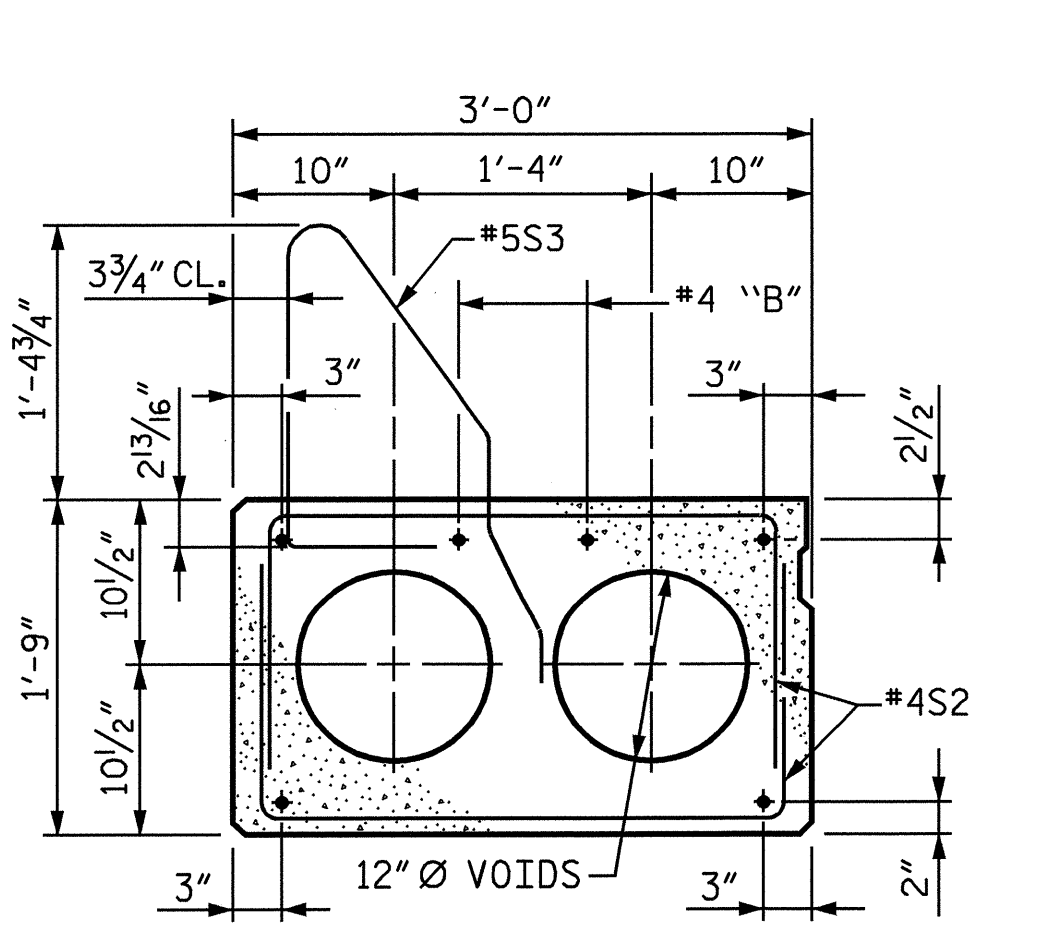

EXTERIOR SLAB SECTION

(FOR PRESTRESSED STRAND LAYOUT, SEE INTERIOR SLAB SECTION)

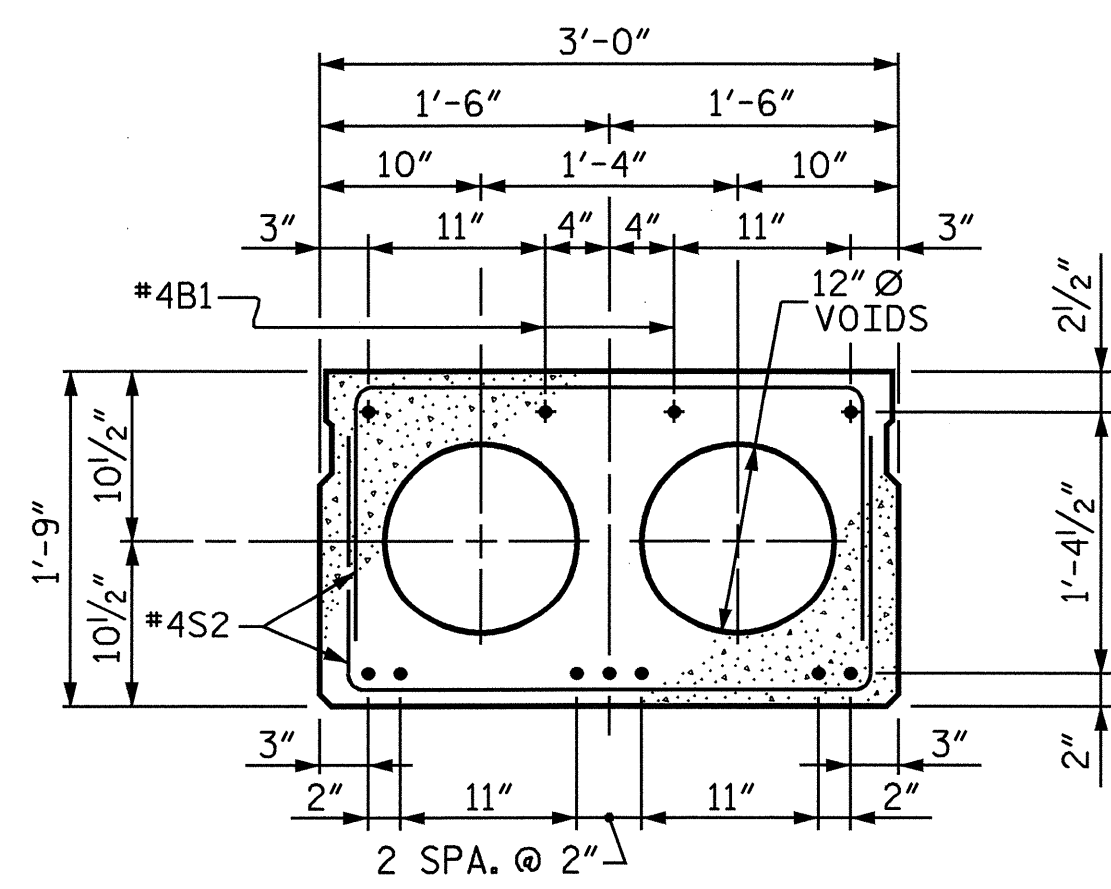

INTERIOR SLAB SECTION (SPANS A & C)

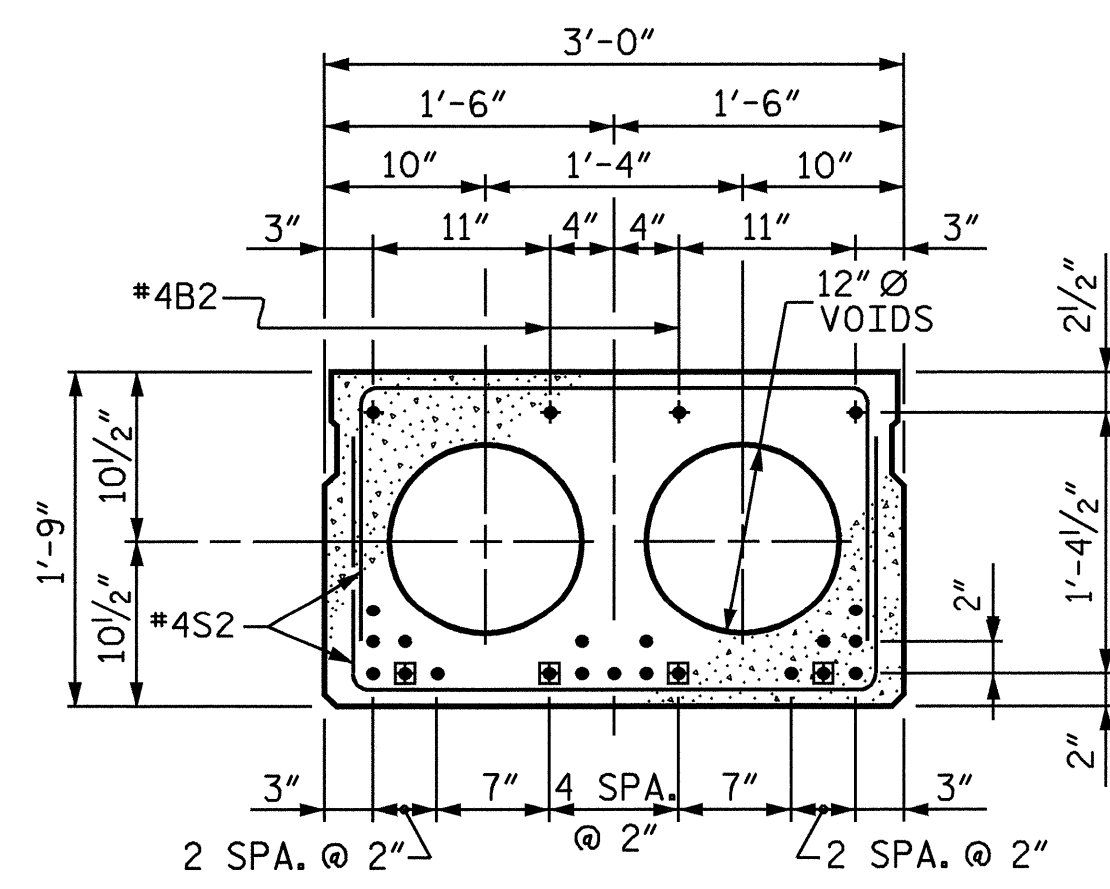

INTERIOR SLAB SECTION (SPAN B ONLY)

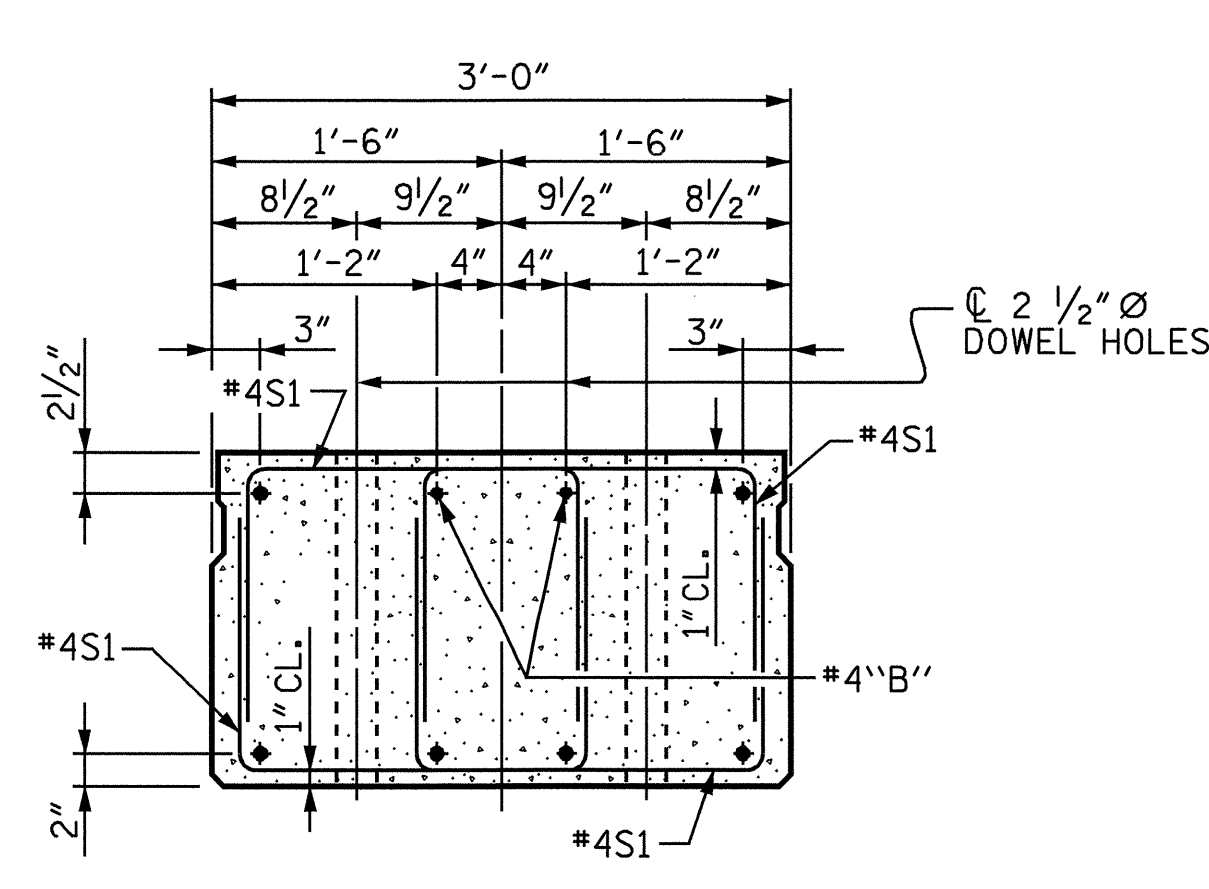

END ELEVATION

(SHOWING PLACEMENT OF DOUBLE STIRRUPS & LOCATION OF DOWEL HOLES) (STRAND LAYOUT NOT SHOWN) (INTERIOR SLAB SECTION SHOWN-EXTERIOR SLAB SECTION SIMILAR EXCEPT SHEAR KEY LOCATION)

1/2" Ø LOW RELAXATION STRAND LAYOUT

BOND SHALL BE BROKEN ON THESE STRANDS FOR A DISTANCE OF 4'-0" FROM THE END OF THE CORED SLAB UNIT. SEE STANDARD SPECIFICATIONS ARTICLE 1078-7.

PROJECT NO. B-4134
 HALIFAX COUNTY
 STATION: 14+23.00 -L-

SHEET 1 OF 5

STATE OF NORTH CAROLINA
 DEPARTMENT OF TRANSPORTATION
 RALEIGH

3'-0" X 1'-9" PRESTRESSED CONCRETE CORED SLAB UNIT

REVISIONS						SHEET NO.	
NO.	BY:	DATE:	NO.	BY:	DATE:	S-4	
1			3			TOTAL SHEETS 23	
2			4				

