

**EDI MODEL MMU-16E  
MALFUNCTION MANAGEMENT UNIT  
PROGRAMMING DETAIL**

(program card and set switches as shown below)

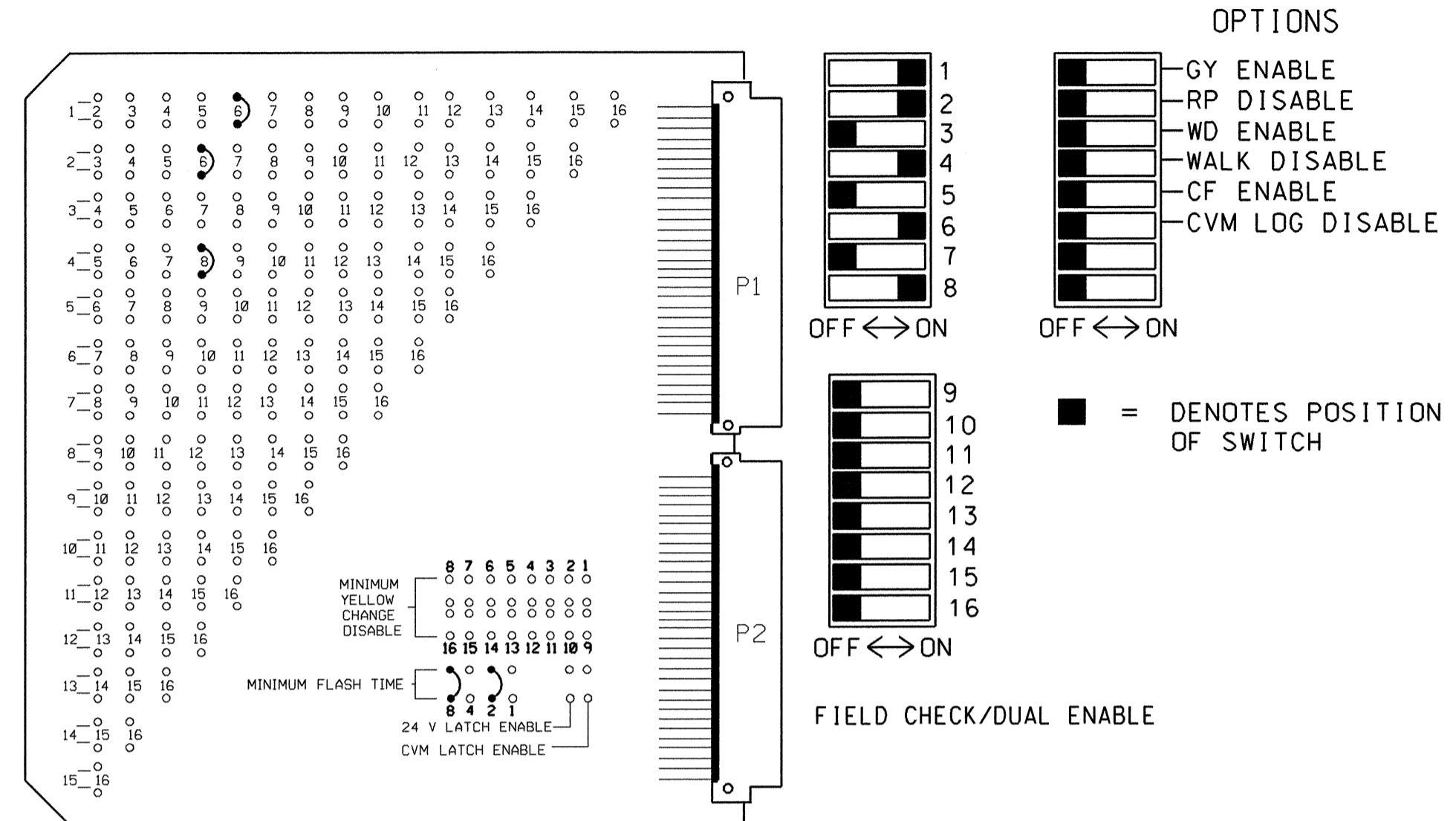

- NOTES**
- TO PREVENT "FLASH-CONFLICT" PROBLEMS, WIRE ALL UNUSED LOAD SWITCHES TO FLASH RED. VERIFY THAT SIGNAL HEADS FLASH IN ACCORDANCE WITH THE SIGNAL PLANS.
  - TO PREVENT RED FAILURES ON UNUSED MONITOR CHANNELS, TIE UNUSED LOAD SWITCH RED OUTPUTS 3,5,7,9,10,11,12,13,14, 15 & 16 TO LOAD SWITCH AC+ BY INSERTING A JUMPER PLUG IN THE UNUSED LOAD SWITCH SOCKET FROM PIN 1 (LS AC+) TO PIN 3 (RED OUT). MAKE SURE ALL FLASH TRANSFER RELAYS ARE IN PLACE.
  - PROGRAM CONTROLLER TO START UP IN PHASES 2 AND 6 GREEN.
  - SET POWER-UP FLASH TIME TO 10 SECONDS AND IMPLEMENT ON THE MALFUNCTION MANAGEMENT UNIT. SET CONTROLLER POWER-UP FLASH TIME TO 0 SECONDS.
  - ENABLE SIMULTANEOUS GAP-OUT FEATURE, ON CONTROLLER UNIT, FOR ALL PHASES.
  - PROGRAM DETECTORS IN ACCORDANCE WITH THE MANUFACTURER'S INSTRUCTIONS TO ACCOMPLISH THE DETECTION SCHEMES SHOWN ON THE SIGNAL DESIGN PLANS.
  - PROGRAM DETECTOR CALL DELAY AND EXTENSION TIMING ON THE CONTROLLER, UNLESS OTHERWISE SPECIFIED.
  - SET ALL DETECTOR CARD UNIT CHANNELS TO "PRESENCE" MODE.
  - PROGRAM PHASES 4 AND 8, ON CONTROLLER UNIT, FOR DUAL ENTRY.
  - PROGRAM AND WIRE THIS CONTROLLER AND CABINET TO BE PART OF THE HIGH POINT CITY SIGNAL SYSTEM. THE CONTRACTOR IS RESPONSIBLE FOR THE PROPER INTERCONNECTION AND OPERATION OF THIS SIGNAL WITHIN THE SYSTEM.

**FIELD CONNECTION HOOK-UP CHART**

PHASE	1	2	3	4	5	6	7	8	OLA	OLB	OLC	OLD	2 PED	4 PED	6 PED	8 PED
SIGNAL HEAD NO.	6I,82	2I,22,23	NU	4I,42	NU	6I,62	NU	8I,82	NU	NU	NU	NU	NU	NU	NU	NU
GREEN		2G		4G		6G		8G								
YELLOW		2Y		4Y		6Y		8Y								
RED	*	2R		4R		6R		8R								
RED ARROW																
YELLOW ARROW	1Y															
GREEN ARROW	1G															

NU = NOT USED  
 \* A LOAD RESISTOR SHALL BE INSTALLED ON LOAD SWITCH I RED FIELD TERMINAL. REFER TO LOAD RESISTOR INSTALLATION DETAIL THIS SHEET.

MMU PROGRAMMING CARD

**DETECTOR RACK SET-UP DETAIL**

INSERT DETECTOR CARDS IN RACK ACCORDING TO THE DETAIL SHOWN BELOW. PARTICULAR DETECTOR CHANNELS WILL CALL PHASES INDICATED.

BIU	CH1	CH1	CH1	CH1	CH1	CH1	SLOT	SLOT	POWER SUPPLY AREA
	L3 ø1	L1 ø1	L7 ø4	L5 ø2	L11 ø8	L9 ø6			
	CH2	CH2	CH2	CH2	CH2	CH2	EMPTY	EMPTY	
	L4 ø2	L2 ø6	L8 ø4	L6 ø2	L12 NOT USED	L10 ø6			
		*		*					

WIRE LOOPS TO TERMINALS ON LOOP PANEL AS SHOWN IN THE CHART BELOW

LOOP NO.	LOOP PANEL TERMINALS
1A	L1A, L1B
1A	L2A, L2B
1B	L3A, L3B
2A,2B	L4A, L4B
2C,2D	L5A, L5B
2E	L6A, L6B
4A	L7A, L7B
4B	L8A, L8B
6A,6B	L9A, L9B
6C,6D	L10A, L10B
8A	L11A, L11B
NU	L12A, L12B
---	L13A, L13B
---	L14A, L14B
---	L15A, L15B
---	L16A, L16B

**NOTE**  
 BE SURE TO PROGRAM DETECTOR TYPES AND TIMERS (EXTEND AND DELAY) AS SHOWN ON THE SIGNAL PLANS.

PROGRAM CONTROLLER DETECTORS ACCORDING TO THE SCHEDULE SHOWN IN THE CHART BELOW

CONTROLLER DETECTOR NO.	FUNCTION	TIMING	
		FEATURE	TIME (SEC)
1	ø1	DELAY	15
2*	ø6	DELAY	3
3	ø1	DELAY	15
4	ø2	EXTEND	1.8
5	ø2	---	---
6*	ø2	DELAY	3
7	ø4	DELAY	3
8	ø4	DELAY	10
9	ø6	EXTEND	1.8
10	ø6	---	---
11	ø8	DELAY	3
12	NU	---	---
13	---	---	---
14	---	---	---
15	---	---	---
16	---	---	---

CONTROLLER SYS. DET. NO.	LOCAL CONT. DETECTOR NO.
1	
2	
3	
4	
5	
6	
7	
8	

\* THIS DETECTOR IS EQUIPPED WITH DELAY AND EXTEND TIMER. TIMING REQUIRED FOR THIS DETECTOR CHANNEL SHALL BE PROGRAMMED ON THE DETECTOR UNIT, NOT THE CONTROLLER.

**EQUIPMENT INFORMATION**

CONTROLLER.....PEEK TRAFFIC 3000  
 CABINET.....PEEK TRAFFIC NC-6 [TS2-1]  
 CABINET MOUNT.....BASE  
 LOADBAY POSITIONS.....16  
 LOAD SWITCHES USED.....1, 2, 4, 6, 8  
 PHASES USED.....1, 2, 4, 6, 8  
 OL/A.....NOT USED  
 OL/B.....NOT USED  
 OL/C.....NOT USED  
 OL/D.....NOT USED

**LOAD RESISTOR INSTALLATION DETAIL**

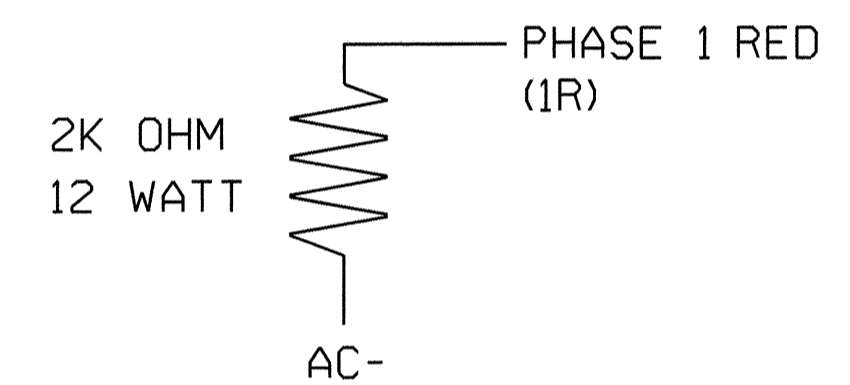

NOTE: THE PURPOSE OF THIS RESISTOR IS TO LOAD THE CHANNEL RED MONITOR INPUT IN ORDER FOR THE MALFUNCTION MANAGEMENT UNIT TO USE THE FULL SIGNAL SEQUENCE MONITORING CAPABILITY ON PHASES THAT DO NOT USE THE RED DISPLAY IN THE FIELD.

HIGH POINT CITY SIGNAL SYSTEM  
 INTERSECTION I.D. 708

THIS ELECTRICAL DETAIL IS FOR THE SIGNAL DESIGN: 07-1467  
 DESIGNED: 03/19/2004  
 SEALED: 06/15/2004  
 REVISED:

 <b>PLANS PREPARED BY :</b> <b>RUMMEL KLEPPER &amp; KAHL, LLP</b> <i>consulting engineers</i> 5800 FARINGDON PLACE SUITE 105 RALEIGH, NORTH CAROLINA 27609-3960 FOR <b>DIVISION OF HIGHWAYS</b>	 Traffic Engineering and Safety Systems Branch DEPARTMENT OF TRANSPORTATION Signal Management Section 122 N. McDowell St., Raleigh, NC 27603	SR 1113 (KIVETT DRIVE) AT PENDLETON STREET		SEAL NORTH CAROLINA PROFESSIONAL ENGINEER SEAL 07438 ENGINEER JAMES O. DEATON
		DIVISION 07 GUILFORD COUNTY HIGH POINT		
PREPARED BY: M W YALCH REVISIONS: _____ INIT. DATE		PLAN DATE: MAY 2004 REVIEWED BY: J O DEATON REVIEWED BY: _____		SIG. INVENTORY NO. 07-1467